

**MICROBUL-S-PC  
MICRO VICKERS HARDNESS TESTER**

OPERATION MANUAL



**BMS Bulut Makina Sanayi ve Ticaret Ltd. Şti.**

Kocaeli KOBİ Organize Sanayi Bölgesi  
Köseler Mahallesi, 6.Cadde No: 20/2 Dilovası / KOCAELİ / TURKEY  
Phone: +90 262 502 97 73-76 / +90 262 503 06 51  
Web: [www.bulutmak.com](http://www.bulutmak.com) e-mail: [bms@bulutmak.com](mailto:bms@bulutmak.com)

1	Introduction.....	2
1.1	machine overview .....	2
1.2	Principle of micro-Vickers and Knoop hardness .....	2
1.2.1	1 HV.....	2
1.2.2	Knoop's HK.....	2
2	Main technical parameters .....	3
2.1	Main parameters of the machine.....	3
3	Installations and debugging of instrument .....	5
3.1	Working conditions of hardness tester .....	5
3.2	Unpacking and installation.....	5
4	Panel key functions introduced .....	6
4.1	Function of each key .....	6
4.2	Selection of test force.....	8
4.3	Energy saving model.....	8
5	The use of hardness testers.....	8
5.1	The operation of hardness tester: .....	8
5.1.1	Digital manual turret testing process: .....	8
6	Maintenance and operation notes of hardness tester .....	9
6.1	Light source maintenance .....	9
6.2	Replacement of fuse.....	9
6.3	Diamond indenter.....	10
6.4	Sample.....	10
6.5	Force, indentation size choice .....	12
6.6	Printer.....	12
7	Packing list.....	13

# 1 Introduction

## 1.1 machine overview

First of all, thank you for choosing our products and browsing the brochure.

The digital micro vickers hardness tester is suitable for testing metal structures, including tiny parts, plates, foils, wires, thin hardened layers and electroplated coatings. It can also be used to test Rockwell test methods such as glass, jewelry and ceramics, and other non-metallic materials which are not tested on relatively large test force tests. In particular, it follows the structure of metals to test the internal hardness of materials such as induction, hardening, or carburizing.

Digital display microhardness tester is a new high-tech product of Opto mechatronics. It has the advantages of novel modeling, good reliability, operability and repeatability. It is an ideal product for testing microhardness.

It adopts C language program, high-rate optical measurement system and optical dual channel structure, and photoelectric, optical sensor and other new technologies. By key operation, the length of the indentation can be measured on the key, and the hardness value, scaling ruler, test force, test force, holding time and measurement times can be displayed on the LCD screen.

Digital micro hardness tester can also be configured according to the special needs of users, to measure the indentation and material metallographic tissue shooting, visual measurement device and indentation automatic measuring device, and Knoop hardness measurement.

## 1.2 Principle of micro-Vickers and Knoop hardness

### 1.2.1 1 HV

Hardness test is head with 136 degrees is diamond, to test force (F) surface is pressed into the test object, the time required to maintain test force, unloading test force, indentation diagonal surface with micrometer eyepiece measurement test (d), the average pressure calculation of conical indentation surface area the (N/mm<sup>2</sup>), namely micro-Vickers hardness. (see Figure 1.1).

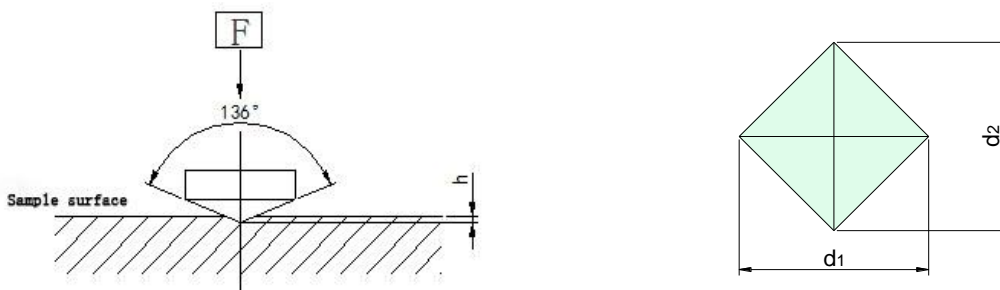

Figure 1.1 micro-Vickers test principle

Formula for Hardness Calculation of micro vickers: 
$$HV = 0.1891 \frac{F}{d^2}$$
 Formula (1-1)

In style:

HV - micro-Vickers hardness

F -N

D-- Indentation, the average of two diagonal (D1, D2) lengths, mm

The relation between HV indentation depth h and diagonal D:  $h=d/7$  formula (1-2)

Note that when the test force is kgf:

$$HV = 1.854 \frac{F}{d^2}$$

Formula (1-3)

### 1.2.2 Knoop's HK

The principle of Knoop's experiment is the same as that of micro vickers, except that its head is different from micro vickers. The indentation perpendicular to the surface of the specimen is a diamond in shape, and the ratio of the length

of the two diagonals is about 7 to 1 (see Figure 1.2). Due to the geometric characteristics of the indenter, the diagonal accuracy is higher when the test force is small. The indentation has a very shallow depth and is approximately a long diagonal 1/30. Due to this characteristic, Knoop test is suitable for testing the hardness of thin coating, surface hardening layer, sheet metal, decarburization layer and hard fragile metal.

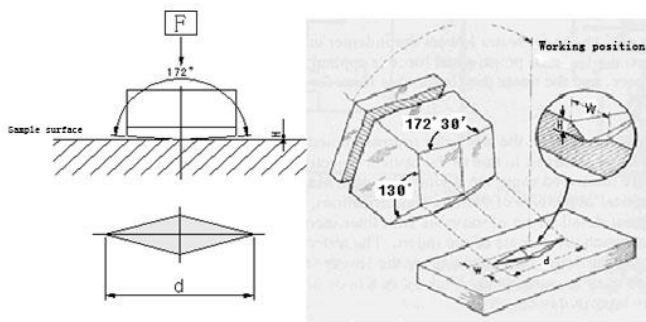

Fig 1.2 principle of Knoop test

Calculation formula of Knoop hardness: 
$$HK = 1.4509 \frac{F}{d^2}$$
 (formula 1-4)

In style:

HK Knoop hardness

F --N

D-- Indentation diagonal length, mm

The relation between HK indentation depth h and diagonal D:  $h = d/30$  (formula 1-5)

When the test force is kgf: 
$$HK = 14.229 \frac{F}{d^2}$$
 (formula 1-6)

## 2 Main technical parameters

### 2.1 Main parameters of the machine

1 series of test force:

Test force of 8: This machine uses KGF units, see Table 2.1

Table 2.1

Kgf	0.01	0.025	0.05	0.1	0.2	0.3	0.5	1
N	0.098	0.245	0.49	0.98	1.96	2.94	4.90	9.80

So, the micro vickers rulers are: HV0.01, HV0.025, HV0.05, HV0.1, HV0.2, HV0.3, HV0.5, HV1

2 Hardness indication errors:

This machine hardness measuring range: 5-3000HV, accuracy meets or is higher than GB/T4340.2, see table 2.2

Table 2.2

hard degree symbol Number	maximum error A percentage expressed as a standard block specifying a hardness value												
	hardness, HV												
	50	100	150	200	250	300	350	400	450	500	600	700	800
HV0.01													
HV0.02	8	10											
HV0.05	6	8	9	10									
HV0.1	5	6	7	8	8	9	10	10	11				
HV0.2		4		6		8		9		10	11	11	12
HV0.3		4		5		6		7		8	9	10	10
HV0.5		3		5		5		6		6	7	7	8
HV1		3		4		4		4		5	5	5	6

Note:

1. When the indentation diagonal is less than 0.020mm, the error value is not given in the table.
2. For the middle value, the maximum allowable error can be obtained by interpolation.
3. The median value of the table is given by the maximum error of 2% of the diagonal average of

The contents of the table are extracted from GB/T4340.2.

Optical system: see Table 2.3

Table 2.3

Objective lens	10× (observation)	40× (measure)
eyepiece	10×	
Total magnification	100× (observation)	400× (measure)
Measurement resolution	0.03125μm	
Halogen brightness	20 stage adjustable	

When the machine does not operate for more than 30 minutes, the halogen light will turn off and press any key to wake up.

4. Test force application method: automatic loading and unloading test force

5. The load time to secure the test: 5 ~ 60s (each second as a unit)

6. Max height of test piece: 110mm

7. from the center of the head to the outer wall distance: 110mm

8. Host weight: approx. 40Kg

9. Power: AC220V/50Hz

10. Overall size: (long \* width \* height) (500 \* 250 \* 560) mm

11. XY platform

XY platform parameters are shown in Table 2.4

Table 2.4

measurement	100×100mm
Trip	25×25mm
Resolving power	0.01mm

12 digital manual turret and digital automatic turret difference:

Digital manual turret micro vickers tester - Test - measuring position switch by manual turntable.

The observation of digital automatic turret Vivtorinox hardness tester the test and measurement position switch are completed by automatic turret, and can also satisfy manual and jog turntable operation.

### 3 Installations and debugging of instrument

#### 3.1 Working conditions of hardness tester

in the range of room temperature (23 + 5) DEG c;

placed horizontally on a firm foundation;

a non-vibrating environment;

in a non-vibrating environment;

indoor relative humidity is not greater than 65%.

#### 3.2 Unpacking and installation

The names of each item on the host are shown in Table 3.1

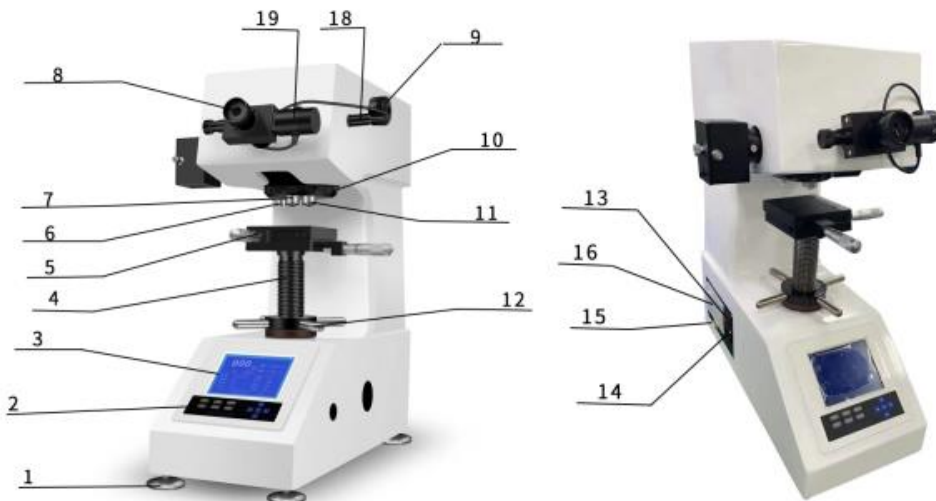

Table 3.1 Master shape of hardness tester

Table 3.1 Name of each item

1. level screw	2.operation button	3. display	4. lifting screw	5. cross test stand
6. press head	7. 10 <sup>x</sup> objective	8 Camera	9. change hand wheel	10. turret
11.40 <sup>x</sup> Objective lense	12. focus hand wheel	13. power switch	14. power outlet	15. RS232
16. printer	17. lamp room			

The installation and debugging steps are as follows:

remove the outer packing box, remove the hardness master and accessory box (see Figure 3.1).

places the hardness tester on the special table and remove the horizontal screw (1) from the attachment box at the

bottom of the main engine.

removes the cover (12), in the machine above rotary screw and screw to shock four

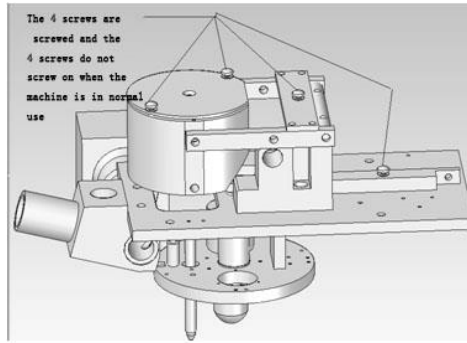

Figure 3.2 removing the 4 screw position drawings

take the weight cap, remove the weights and weights from the enclosure, and place six weights from small to large on the weight shaft. When installing, clean the weight, the axle and the weight first, so that it cannot be stained with dirt. grasp the top of the counterweight shaft, place it in the weight case, and turn the weight axis so that the cross pin is placed in the V groove

(Figure 3.3). The hole on the end cap is aligned with the weight shaft so that the step is loaded inside the case and can rotate.

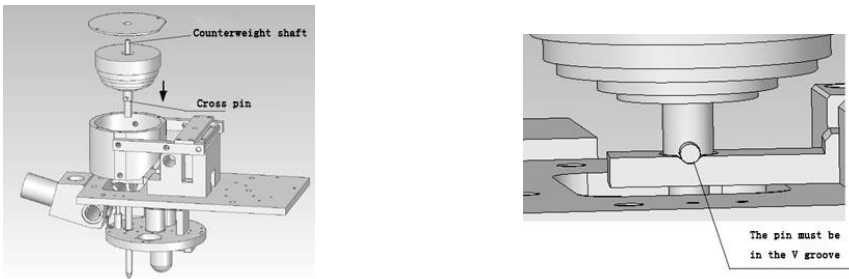

Fig 3.3 the placement of weights and weights

The rotates the handwheel (9) to make the weight housing flexible in the positioning bucket. Then cover the top (12). pull out the dust cover and remove the camera (8) from the attachment box. It is placed in the direction (Fig. 1) and inserted into the hole and inserted into the bottom.

remove the cross-test stand (5) from the attachment box and wipe off the rust proof oil. Insert its shaft into the lifting screw (4) hole and lock the screw.

remove the level gauge from the attachment box and place it on the cross-test table (5). Adjust the screw (1) to the level (bubble center).

## 4 Panel key functions introduced

### 4.1 Function of each key

Figure 4-1 shows the front panel of the digital microhardness tester. The upper part of the graph is LCD, and the details will be illustrated in the following sections. The lower half of the diagram is the keyboard. This chapter will give you a detailed description of the functions of the keys on the keyboard (this book only describes the Chinese interface, and so does the English operation).



Note: the left and right arrows in the face key are the automatic turret objective lens and the conversion key. When entering the menu, the left, right and upper and lower arrows are selected keys.

ESC

Return key: returns to the previous interface and press this key to convert the HV、HK. in the main interface.

OK

Confirmation key: select the function in the menu and enter the number, press this button to confirm the input.

Light brightness Key: brightness by pressing<↓> and<↑>: brightness selection ↑ is increase and ↓ is decrease. The brightness of the light has the function of starting memory.

MENU

Menu: conversion scale, guaranteed time, maximum number of tests, viewing data, time and date, unit selection, language selection, recovery of the categories of menus;

Conversion ruler: menu into the ruler selection bar press OK key, then press left, right-click selection and press OK key to determine.

Load time: menu into the load-keeping time bar press OK key, then press up and down key add and subtract, then press OK key;

Maximum number of tests: menu into the maximum number of tests press up, down key adds or subtract select the required value by the OK key to determine.

Unit selection: menu into the ruler selection bar press OK key, then press left, right-click selection Kg、N then press OK key;

**Date:** menu into the time date bar press the OK key, then press left, right-click to select the time date and then press up, down key to add or subtract the time date.

**Data output:** menu into the data output bar press OK key, and then press OK key to display the pre-operation data. If you have a built-in printer, press the OK key to print out the pre-operation data;

**Language selection:** menu into language selection, left and right key selection, press OK key to determine.

**Restore the factory:** press this button to restore the factory settings;

START

**Start button:** press this button to start loading: manual turret type to head to the front and then press the button, when the automatic turret machine head and no matter what position, just press this button head will automatically go to the front. But make sure that the head does not touch any object. Otherwise, it will damage the head.

DEL

**Delete key:** By pressing <DELETE> once, you can clear the current test record under the main menu, and you can see a decrease in the number of measurements. If you press <DELETE> for a long time, all historical test records will be cleared.

PRINT

**Print key:** press this button to enter the view measurement database, press the OK button to print out the measurement data. Or RS232 output will execute. If you choose the RS232 serial data output, please connect to the PC computer, run the super terminal on the PC computer, and press <PRINT> to perform. The serial data communication format is 9600, N, 8, 1. Refer to the following RS232 operation.

## 4.2 Selection of test force

When you turn the instrument on the test force change handwheel, select the new test force, the main menu, the upper right corner of the test force value changes immediately. After the test force is selected, the new test force is loaded into the system. The system clears previous test results and new test force tests will begin.

## 4.3 Energy saving model

This hardness meter will automatically enter energy saving mode after 10 minutes without use, automatically turn off the light source. The user can wake up the energy saving mode of to wake up the hardness meter energy saving mode, or rotate the right drum to wake up the hardness meter light source, for normal testing.

# 5 The use of hardness testers

## 5.1 The operation of hardness tester:

The process of measuring hardness by hardness is shown in Figure 5.1

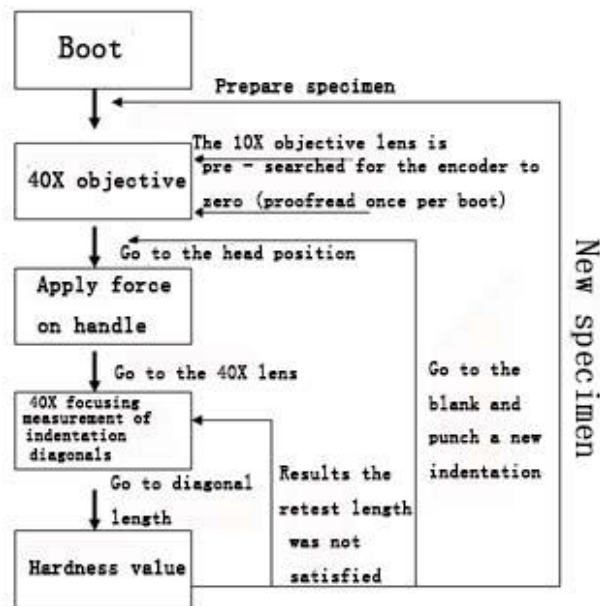

Fig. 5.1 measurement process of the Vickers hardness tester

### 5.1.1 Digital manual turret testing process:

- 1) Plug in the power and turn on the power switch. There is an interface on the screen, where data can be modified. For example: hardness scale (HV, HK) selection, Hardness Conversion selection, time selection, light selection, press the button to meet the requirements.
- 2) The rotation change handwheel (9) makes the test force meet the requirements of the selection, and the force value of the changing hand wheel (9) is consistent with the force value displayed on the screen. Rotating the handwheel transform (9), carefully and slowly. When rotating to the maximum force 1kgf, the position of the rotation is in the end, and cannot continue to turn forward. It should turn in reverse direction. When it reaches the minimum force value 0.01kgf, it should also reverse rotation.
- 3) 10s is the most commonly used test force holding time, but also according to the need to enter the menu, select the time to load, according to the upper and lower arrows to add and subtract, each press a change of 1 second, + + Plus, - - minus.
- 4) As field source is too dark or too light, you can press < > and < = >: brightness selection + is increase decrease.
- 5) Turn the turret (10) so that the 40-x objective lens (11) is in the front position (the total magnification of the optical system is 400 x, in the measuring state).
- 6) Standard test block or specimen on the cross platform (5), rotating wheel (12) so that the test specimen from the rise, when the objective lens (11) is about 1-2mm (don't touch the lens), and then use the camera (8) eye observation. Bright spot in the camera field of view, that the focal plane is coming, you should slow the rise or fall of trace test, observation to the sample surface imaging clearly until the camera, then complete the process of focusing. The standard test block surface is very smooth, for beginners to find the surface of the specimen is

difficult, then you can take over the specimen (rough set up), to find the sample surface and then turn back to the test surface.

If you want to observe the larger field of view on the surface of the sample, you can turn the 10-x objective lens (7) to the front position. At this time, the total magnification of the optical path system is 100 x, which is in the observation state.

Note: be careful when testing the irregular, and prevent the pressure head hit and damaged head specimen.

- 7) The head (6) to the front position, to feel the turret (10) has been positioned to be turning slowly and carefully, to prevent excessive shock, the head top and the specimen plane focusing the distance is about 0.4 ~ 0.5mm.
- 8) According to the "START" key, the application of the test force (motor), appears on the screen and unloading progress; when the progress bar is completed, motor end tone "drop" a sound, d1:0 appears on the screen for measurement.

Warning: when the motor is working, do not move the test piece or turn the turret. It must wait until the end of the loading and unloading can be moved, otherwise it will damage the instrument.

## 6 Maintenance and operation notes of hardness tester

### 6.1 Light source maintenance

When the light bulb is broken, please replace the new bulb as follows:

please cut off the electric power first, so as not to get an electric shock;

counter clockwise to loosen the screw 1; see Figure 6.1

according to the direction of the arrow 1 push back cover, click the arrow 2 direction of rotation, remove the back cover; see figure 6.2.

pull up a bad light bulb and replace it with a new light bulb. See figure 6.3.

wipe the surface of the new bulb with a soft cloth. Do not touch the surface of the bulb with your hands;

according to the direction indicated by the arrow 1 push back cover, click the arrow 2 direction of rotation on the back cover. See figure 6.4.

turn on the power switch.

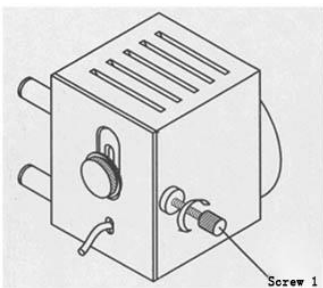

Figure 6.1 unscrew the screws

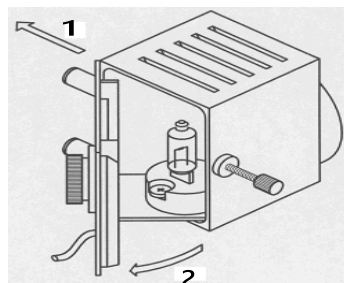

Figure 6.2 take off the back cover

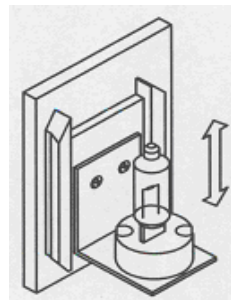

Figure 6.3 turn on the new light bulb

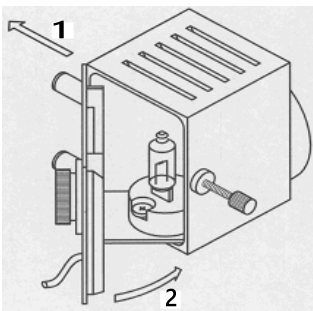

Figure 6.4 cover the back cover

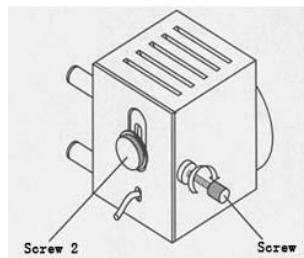

Figure 6.5 adjusting screw

### 6.2 Replacement of fuse

When the machine fuse is broken, please replace it as follows:

cut off the power supply and pull the power cord out of the seat. Insert a screwdriver into the center of the connector according to the diagram, and lever out the fuse holder.

remove the fuse holder from the incoming connector. Take out the fuse and see if the inside filament is broken. If you

can't decide whether the fuse is broken or not, you can check with the ohmmeter to see if the filament is good  
replace the new fuse and install it

The fuse is mounted inside the fuse holder to protect the hardness meter from damage by power, voltage, or internal short circuits. If something happens to cause the fuse to burn again, please contact the maintenance personnel immediately.

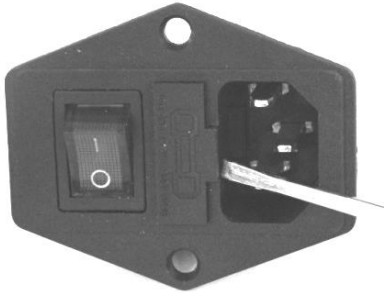

Figure 6.6 knocking on fuse holder



Figure 6.7 replacing fuse

### 6.3 Diamond indenter

the pressure head (7) and the indenter are very important parts of the instrument, so be careful not to touch the indenter when operating.

in order to ensure the test precision, the pressure head should ensure clean, when stained with dirt or dust may be degreased cotton stained with alcohol or ether (industrial), the pressure head at the top carefully and gently wipe clean. if you want to replace the pressure head, please do not disassemble, please contact the maintenance man.

### 6.4 Sample

if you suspect that the machine can be used to check the hardness, standard hardness blocks, proofreading hardness blocks to literally block, the hardness can be measured as oil rub, usually the first test point is not only effective, second points.

the surface of the sample must be clean. If the surface is contaminated with grease and dirt, it will affect the accuracy of the measurement. When cleaning the sample, wipe it with alcohol or ether.

when the sample is small or thin filaments, respectively, clamping table and sheet clamping table and flat clamping table holding filaments, on the cross-test rig for testing; if it is not a small clamping specimen, specimen will be inlaid polishing after test.

To ensure the correctness of the test, the thickness of the sample must be guaranteed. Test piece according to the national standard

The thickness must be no less than 8~10 times the indentation depth. Then how do you know that the sample meets the requirements? Here are some methods.

Direct observation:

Test the specimen according to the requirements, and observe the edges and the back (support surface) of the specimen after the test. If any traces appear, the test result is invalid.

The thickness of the sample is too thin to meet the requirements of the test. There are two choices at this time. One is to redo the specimen, and some parts cannot be changed. The two is to select the smaller test force, which can only be carried out within the prescribed requirements.

B) Formula calculation method:

Vivtorinox hardness test piece thickness calculation formula:  $H \approx d/7$ .

(C) Look-up table: Table 6.1

Table 6.1 table of minimum thickness and testing force of sample

Minimum thickness/m m	Detection force/N(Kgf)							
	0.049	0.9807	0.1471	0.1961	0.2452	0.4903	0.9807	1.9614
HV	HV0.005	HV0.01	HV0.015	HV0.02	HV0.025	HV0.05	HV0.1	HV0.2
50	0.019	0.028	0.034	0.039	0.043	0.062	0.087	0.123
100	0.013	0.020	0.024	0.028	0.0310	0.043	0.061	0.087
200	0.0097	0.014	0.017	0.020	0.022	0.031	0.043	0.062
300	0.008	0.011	0.014	0.016	0.018	0.025	0.036	0.050
400	0.0069	0.010	0.012	0.014	0.015	0.022	0.031	0.043
500	0.0062	0.0087	0.011	0.012	0.014	0.019	0.028	0.039
600	0.0056	0.008	0.010	0.011	0.013	0.018	0.025	0.036
700	0.0052	0.007	0.0090	0.010	0.012	0.016	0.023	0.033
800	0.0049	0.0069	0.0084	0.0097	0.011	0.015	0.022	0.031
900	0.0045	0.0064	0.0080	0.0091	0.010	0.014	0.021	0.029
1000	0.0043	0.006	0.0075	0.0086	0.009	0.0138	0.019	0.028
1200	0.0039	0.0056	0.0069	0.0079	0.0088	0.013	0.018	0.025
1400	0.0036	0.0052	0.0064	0.0073	0.082	0.012	0.016	0.023

Minimum thickness ' /mm	Detection force/N(Kgf)							
	1.961	2.942	4.903	9.807	19.61	29.42	39.22	49.03
HV	HV0.2	HV0.3	HV0.5	HV1	HV2	HV3	HV4	HV5
50	0.12	0.15	0.19	0.27	0.38	0.47	0.54	0.61
100	0.086	0.13	0.14	0.19	0.28	0.33	0.39	0.43
200	0.062	0.075	0.097	0.14	0.19	0.24	0.27	0.31
300	0.050	0.062	0.080	0.11	0.16	0.19	0.22	0.25
400	0.043	0.053	0.069	0.10	0.14	0.17	0.20	0.22
500	0.039	0.048	0.062	0.09	0.12	0.15	0.17	0.19
600	0.036	0.043	0.057	0.08	0.11	0.14	0.16	0.18
700	0.033	0.040	0.052	0.073	0.10	0.13	0.15	0.16
800	0.031	0.038	0.049	0.069	0.097	0.12	0.14	0.15
900	0.029	0.036	0.046	0.065	0.095	0.11	0.13	0.14
1000	0.028	0.034	0.043	0.060	0.090	0.10	0.12	0.13
1200	0.025	0.031	0.040	0.056	0.079	0.095	0.11	0.12
1400	0.023	0.028	0.037	0.051	0.073	0.090	0.103	0.11

Minimum thickness t/mm	Detection force/N(Kgf)					
	49.03	98.07	196.1	294.2	490.3	980.7
HV	HV5	HV10	HV20	HV30	HV50	HV100
50	0.62	0.87	1.23	1.50	1.94	2.75
100	0.43	0.61	0.86	1.06	1.37	1.95
200	0.31	0.43	0.62	0.75	0.97	1.4
300	0.25	0.36	0.50	0.62	0.80	1.2
400	0.22	0.31	0.43	0.53	0.69	1.0
500	0.19	0.28	0.39	0.48	0.61	0.86
600	0.18	0.25	0.36	0.44	0.56	0.80
700	0.16	0.23	0.32	0.40	0.51	0.74
800	0.15	0.22	0.31	0.38	0.49	0.69
900	0.14	0.21	0.29	0.36	0.46	0.64
1000	0.13	0.19	0.28	0.34	0.44	0.62
1200	0.12	0.18	0.25	0.31	0.40	0.56
1400	0.11	0.16	0.23	0.28	0.37	0.52

The production of test pieces shall be carried out according to the requirements of the national standard GB/T4340.

### 6.5 Force, indentation size choice

When measuring the hardness of Vivtorinox, as long as the condition of the specimen is allowed, the large test force should be used as far as possible, and the measurement is relatively accurate. Generally, hard materials use larger test forces; soft materials use smaller test forces.

According to the habit, the indentation diagonal length is about 50um, the most convenient measurement, but also consider the thickness of the material.

Reference: Material thickness  $\geq 1.5 \times$  Indentation diagonal length

For example: material thickness = 0.1mm, then the indentation diagonal length cannot be greater than 0.066mm.

Meet here:  $0.1 \geq 1.5 \times 0.066$

### 6.6 Printer

The digital micro hardness tester is equipped with a thermal printer on the body. The shape of the machine is shown in Figure 6-8.



Figure 6-8 printer outline structure

When the power supply of the hardness tester is switched on, the power indicator lamp will be lit. When the indicator light is flashing, the printing paper has been used up. Please replace it.

Replace printing paper

Printing paper specifications thermal paper roll, paper width 44mm + 0.5 mm

An interior roll diameter is less than 38 mm,

The purpose of the paper is 0.065 mm thick paper, 53-64 g/m<sup>2</sup>  
open the front cover panel of the printer, as shown in figure 6-9.

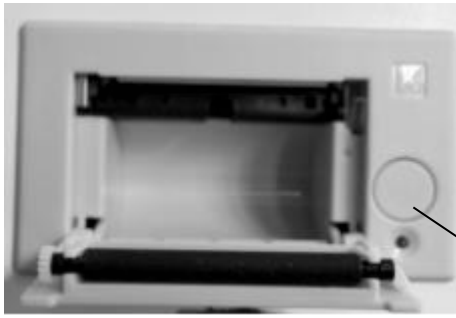

Press the paper button to open the front cover

figure 6-9. open the front cover panel of the printer

remove the paper reel from the printer, such as a paper roll on a printer, and skip this step to the fourth step.

place the new roll of paper onto the paper reel and press the roll into the printer's Guide slot.

cut the end of the paper into the pattern shown in figure 6-10.

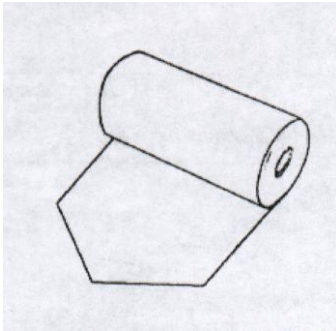

Figure 6-10 paper end design



figure 6-11 put paper back cover front cover

Pull the print end out of the front cover of the printer and out of the paper and cover the front cover plate. As shown in Figure 6-11, you can use it normally.

Note: when printing work, if there is only paper out and no print record, you may put the printing paper installed in reverse, you need to roll out, turn around, and then reinstall according to the above steps.

## 7 Packing list

Host (including micro Vivtorinox head, one, 10X, 40X objective lens each);

Test stand, weights, microscope accessories case;

Weights		6
Weight lever		1
Cross table		1
Level instrument		1
Screwdriver		1
Level adjustment screw		4
External power cord		1
Camera	1	
Micro hardness block	1	
Fuses (1 A)		2
Product qualification certificate	1	
Product instruction manual		1
dust cover		1