

## DIGIROCK-RB-M

Digital Rockwell & Brinell Touchscreen  
Motorized Hardness Tester



**BMS Bulut Makina Sanayi ve Ticaret Ltd. Şti.**

Kocaeli KOBİ Organize Sanayi Bölgesi

Köseler Mahallesi, 6.Cadde No: 20/2 Dilovası / KOCAELİ / TURKEY

Phone: +90 262 502 97 73-76 / +90 262 503 06 51

Web: [www.bulutmak.com](http://www.bulutmak.com) e-mail : [bms@bulutmak.com](mailto:bms@bulutmak.com)

1	Technical Specifications -----	3
2	Standard Accessories -----	3
3	Unpacking Of Equipment -----	3
4	Setting into Operation -----	5
5	Rockwell Hardness Testing ( <i>EN 6508-1, ASTM E18</i> ) -----	5
6	Brinell Hardness Testing ( <i>EN 6506-1, ASTM E10</i> ) -----	6
7	Test Method -----	7
8	Prior to Test -----	8
8.1	Choosing the Test Load -----	8
9	Main Screen -----	9
10	Testing -----	9
11	Test Method -----	9
12	Records -----	9
13	Settings -----	10
14	Calibration -----	15

# 1 Technical Specifications

Pre-load (kgf)	<i>10</i>
Test loads (kgf)	<i>60 100, 150 for Rockwell tests 62,5 187,5 for Brinell tests</i>
Load selection	<i>By load selector disc</i>
Test method	<i>Rockwell and Brinell</i>
Load application	<i>Motorised</i>
Max. Test height	<i>280 mm</i>
Depth of throat	<i>145 mm</i>
Machine dim's	<i>770x520x260 mm</i>
Case dim's	<i>900x590x440 mm</i>
Weight (net/gross)	<i>95 /125 kg</i>

# 2 Standard Accessories

- Rockwell Cone Diamond Indentor
- 1/16" Ball Indentor
- 2,5 mm Ball Indentor
- HRC Test Block
- HRB Test Block
- HB 2,5 / 187,5 Test Block
- Flat Testing Table
- V Testing Anvil For Round Parts
- Hardness Conversion Table
- Wooden Case For Accessories
- Cover
- Allen Spanners
- Rubber Bellow For Elevating Screw
- Instruction Manual
- Calibration Certificate

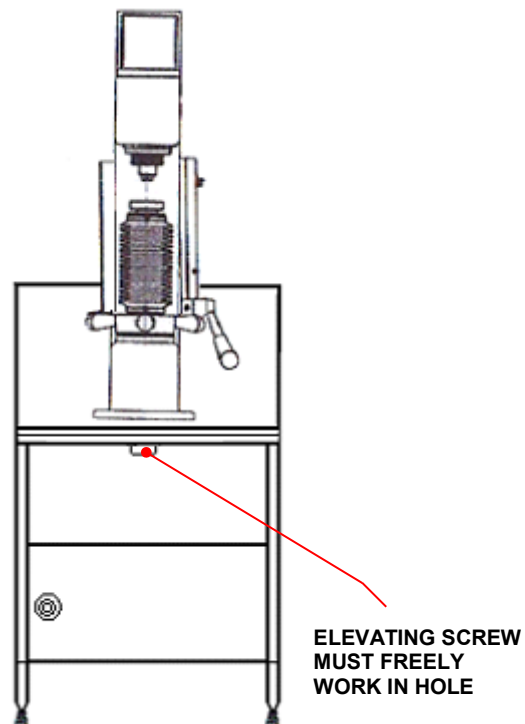
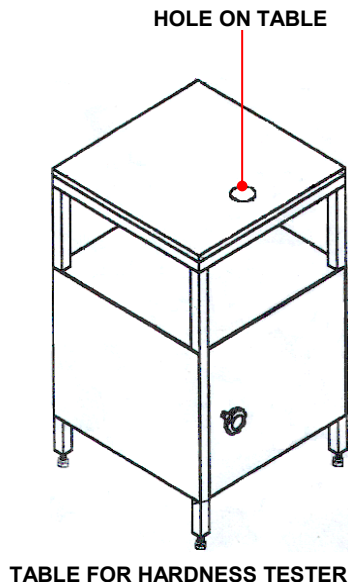

# 3 Unpacking Of Equipment

Unscrew fixing steel sheet plates of upper side to wooden base of case and hold up upper side of wooden case by means of carrying handles. Take out two M8 bolts fastening equipment to lower wooden case. Locate equipment on a special table (see drawing of table enclosed) and fasten two M8 bolts by means of eye bull putting on flat testing table. Open left cover. Take out wooden safety parts. Take out also 3 off M6 bolts of top cover by means of 5 mm special allen key which is in accessory box with care. Take out plastic safety parts. Equipment is now ready for testing.

**TOUCH SCREEN**

**TOP COVER**

**LOAD SELECTOR**

**ELEVATING SCREW**

**ARM OF NUT**



## 4 Setting into Operation

Locate part to be tested on testing table, Insert indenter to holder and choose load by means of load selector disc (according to testing method in attached table).

## 5 Rockwell Hardness Testing (EN 6508-1, ASTM E18)

Rockwell Hardness testing method is evaluated from penetration depth of 120° diamond cone or ball indenter with different dias (please refer to table enclosed).

Below application shows working procedures using Rockwell diamond cone (HRC-HRA etc.)

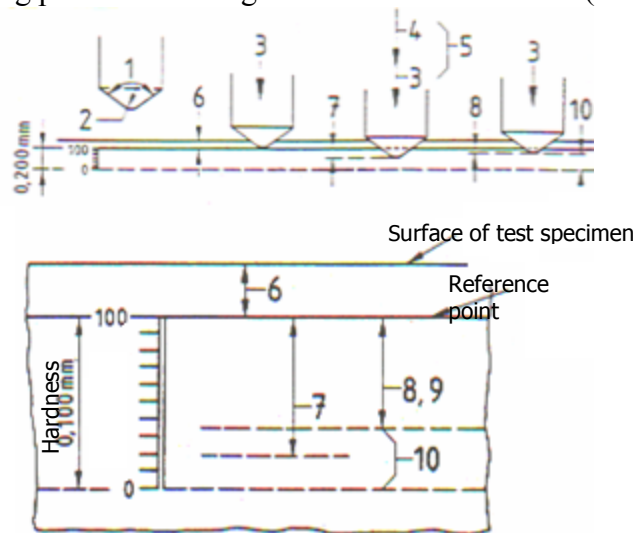

Nr	Symbol	Description
1	0	120 ° Diamond cone
2	0	Radius of diamond tip= 0,2 mm
3	F <sub>0</sub>	Pre-Load
4	F <sub>1</sub>	Additional Load
5	F	Total load F <sub>0</sub> + F <sub>1</sub>
6	t <sub>0</sub>	Depth of penetration under pre-load, mm
7	t <sub>1</sub>	Depth of penetration under additional load, mm
8	t <sub>b</sub>	Increase in depth of penetration from F <sub>1</sub> to F <sub>0</sub> , mm
9	e	Equality as of 0,002 mm increase of depth of penetration e= t <sub>b</sub> / 0,002
10	0	Rockwell hardness = 100-e

Below application shows working procedures using 1/16" ball indenter (HRB etc.)

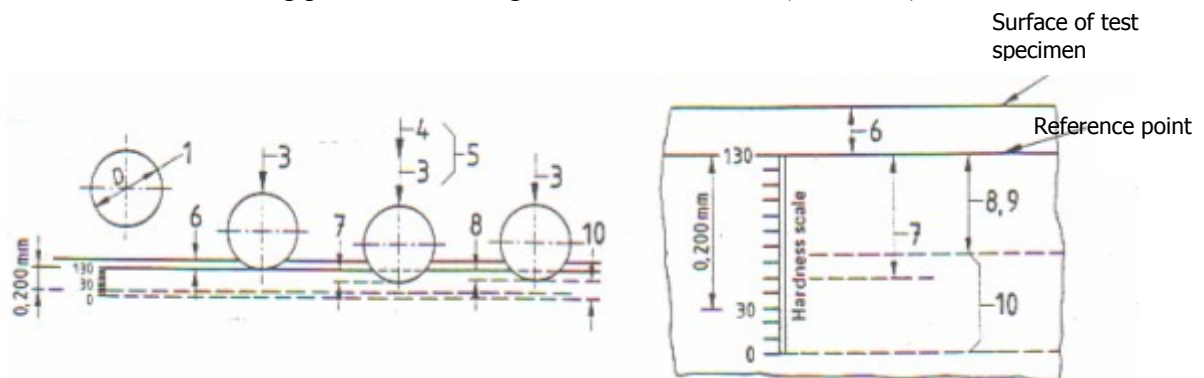

Nr	Symbol	Description
1	D	Ball dia=1/16" =1,5875 mm
3	F <sub>0</sub>	Pre-load
4	F <sub>1</sub>	Additional load
5	F	Total load =F <sub>0</sub> +F <sub>1</sub>
6	t <sub>0</sub>	Depth of penetration under pre-load, mm
7	t <sub>1</sub>	Depth of penetration under additional load, mm
8	t <sub>b</sub>	Increase in depth of penetration from F <sub>1</sub> to F <sub>0</sub> , mm
9	e	Equality as of 0,002 mm increase of depth of penetration e= t <sub>b</sub> / 0,002
10	HRB/HRF	Rockwell hardness= 130-e

**For Rockwell tests**, HRC, HRA, HRD tests Rockwell Diamond indenter to be chosen while 1/16" ball indenter for HRB, HRF, HRG tests (see enclosed table) Using 1/8", 1/4" ball indenters (optional) others tests can be also achieved.

**For Brinell tests**, 2,5 mm ball indenter to be used. Without using optical microscope, it is possible to see Brinell values directly on screen (depth measurement) please see Operational Manual of DIGIROCK for test menu enclosed. Materials to be tested by Brinell methods can easily be chosen in the menu shown below.

## 6 Brinell Hardness Testing (EN 6506-1, ASTM E10)

Brinell hardness testing method is made by different balls depending on material type, thickness and loads applied. Diameters of ball indentations can be evaluated by optical system or portable microscopes. You may also see Brinell values of Aluminum, Copper, Brass (Bronze), Steel, Stainless Steel and Cast Iron directly by DIGIROCK unit without using portable microscope. To do this, pls refer to manual of DIGIROCK for different materials. Insert 2,5 mm indenter to holder. Apply position of load selector disc on suitable load (62,5 kgf or 187,5 kgf) and do the same procedures as like Rockwell . Relations with thickness of specimen, ball dia and material shown in related the table

Thickness of material (mm)	Ball dia(mm)	P=30D <sup>2</sup> Steel, iron, cast iron	P=10D <sup>2</sup> Brass, Bronze, Cupper,Aluminium	P=D <sup>2</sup> Soft cupper	P=5D <sup>2</sup> Lead
6 mm and up	10	3.000 kgf	1.000 kgf	500 kgf	250 kgf
3 mm and up	5	750 kgf	250 kgf	125 kgf	62,5 kgf
1,2 mm and up	2,5	187,5 kgf	62,5 kgf	31,25 kgf	15,625 kgf
0,5 mm and up	1	30 kgf	10 kgf	5 kgf	-

## 7 Test Method

Test method	Indentor	Pre-load (kgf)	Total load (kgf)	Field of application
HRA	Diamond cone	10	60	Surface hardened parts with thin cases ( $\geq 0,4$ mm)
HRB	1/16" ball	10	100	Nonferrous metals, unhardened steels
HRC	Diamond cone	10	150	Hardened steels
HRD	Diamond cone	10	100	Surface hardened parts with medium cases
HRE	1/8" ball	10	100	Aluminum and magnesium alloys, antifriction metals, synthetic metals
HRF	1/16" ball	10	60	Annealed copper alloys, thin sheet metals ( $\geq 0,6$ mm)
HRG	1/16" ball	10	150	Phospor-bronze, malleable iron of medium hardness
HRH	1/8" ball	10	60	Aluminium, zinc, lead, grinding stones
HRK	1/8" ball	10	150	Antifriction and other metals of very low hardness
HRL	1/4" ball	10	60	As HRK and hard rubber
HRM	1/4" ball	10	100	As HRK and HRL, laminated wood
HRP	1/4" ball	10	150	HRK, HRL or HRM and synthetic materials
HRR	1/2" ball	10	60	
HRS	1/2" ball	10	100	
HRV	1/2" ball	10	150	As HRK, HRL, HRM, HRP, HRR or HRS
HR 15 N HR 30 N HR 45 N	Diamond cone	3	15 30 45	As HRA, HRC or HRD, but especially thin case depth ( $\geq 0,18$ mm)
HR15T HR30T HR45T	1/16" ball	3	15 30 45	As HRB, HRF or HRG but especially for thin sheet metals ( $\geq 0,25$ mm)
HR15W HR30W HR45W	1/8" ball	3	15 30 45	For metals with very low hardness and for very thin cases, for example thin linings of antifriction metals, HRX and HRY especially for sintered metals
HR15X HR30X HR45X	1/4" ball	3	15 30 45	
HR15Y HR30Y HR45Y	1/2" ball	3	15 30 45	

## 8 Prior to Test

Using table, choose suitable indenter according to test method to be applied. Locate indenter on holder carefully and gently tighten allen screw using allen key.



### 8.1 Choosing the Test Load

Choose suitable test load on LCD screen in related menu, according to table locate part to be tested on testing anvil.

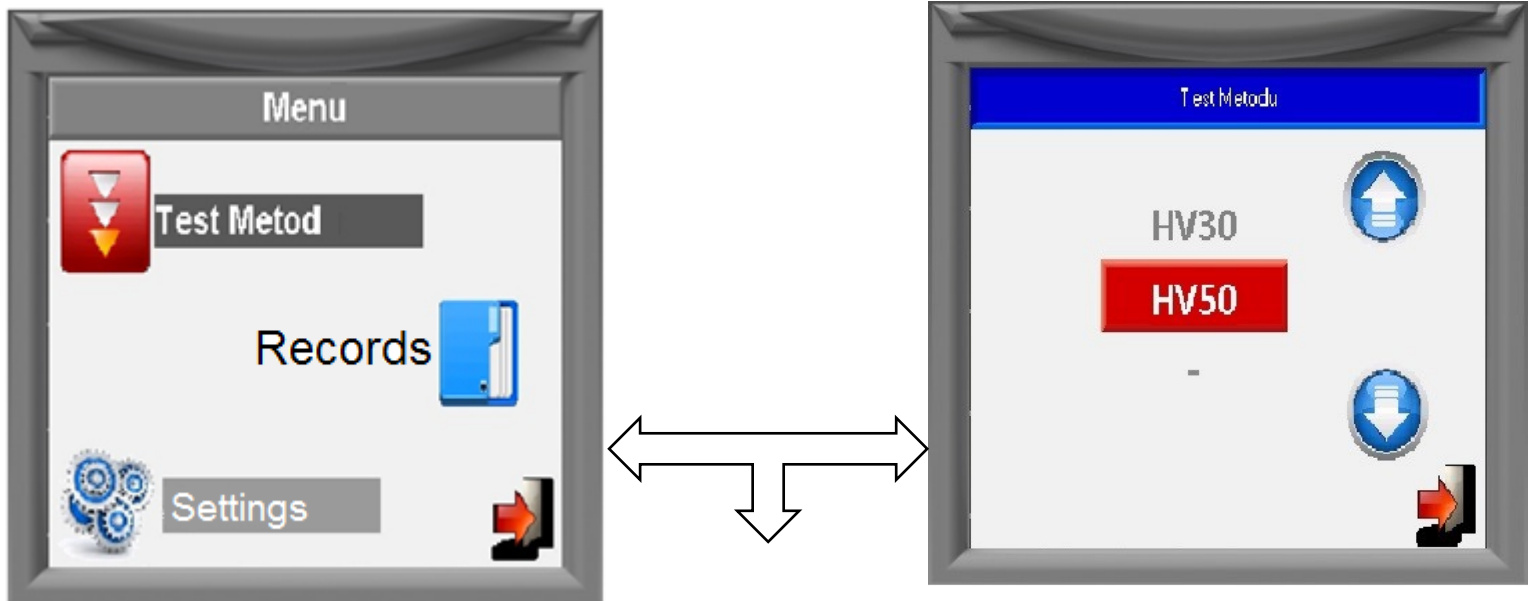

When you push test method on touch screen, test load will be adjusted automatically. Using upper and lower arrows, other test methods can be selected easily. Then, when required method reached, by pushing it can be actuated.

## 9 Main Screen

Connecting to the computer or printer.

Radius correction for Rockwell method

Record no

Test number /total number

Upper and lower tolerances limits sign

Test method

Test result

Hardness conversions



Testing situation

Bargraph

## 10 Testing

Switch on equipment by ON/ OFF button.

Apply pre-load carefully and follow movement of bargraph until it comes to final position. As soon as pre-load position is reached %100 position automatic load application will start. When it is over, unloading will start automatically & machine will come back to pre-load position. Then, value will be shown on the screen.

## 11 Test Method

Using buttons, TEST METHOD menu obtained. And pressing the buttons required test method can be reached.

## 12 Records

RECORDS section, **registration number, name, min, max, mean, standard deviation**, can be seen. When you entered the stored value in the memory, values can be transferred to micro printer or computer.

**NOTE:** The total memory capacity of the device, along with 50 pieces of data below 100 separate entries, a total of 5000 pieces.

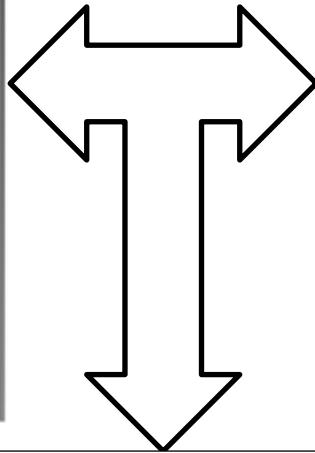

You can see the test records on the main menu, you can delete and transfer saved datas to the printer or computer.

### 13 Settings

The point to settings, **printer, date / time average number of test time, the factory setting, test the lower limit, upper limit test sets such as language selection**, are entered using the function keys.

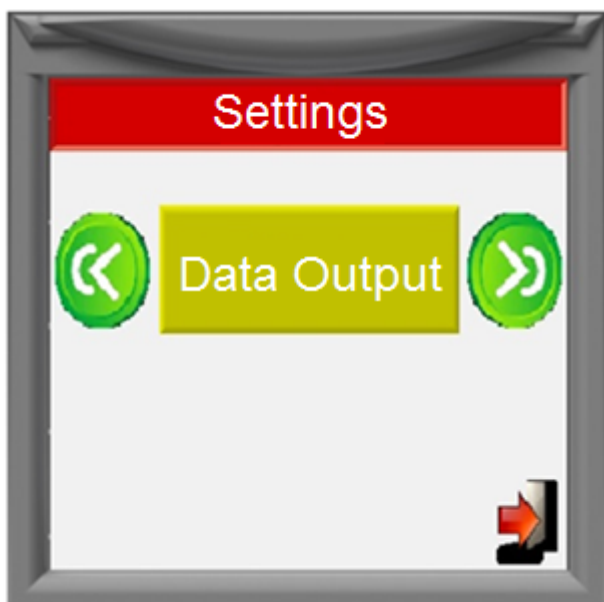
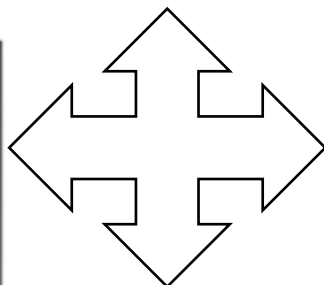

You can edit the following options from the Settings

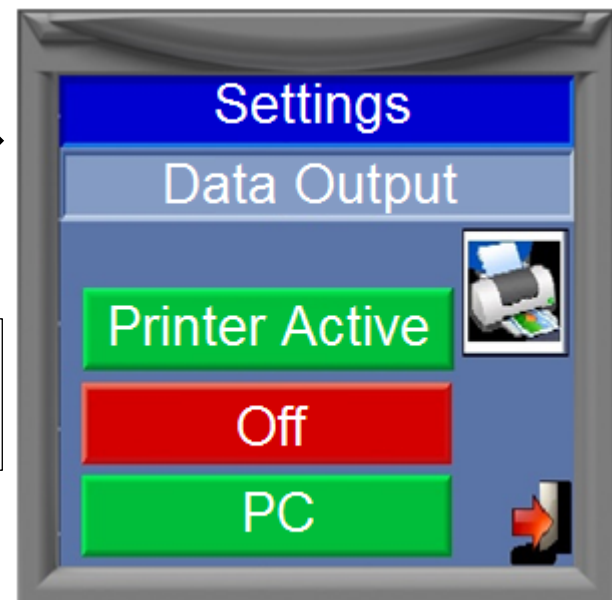

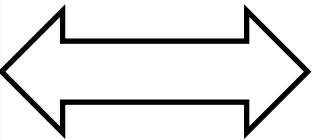
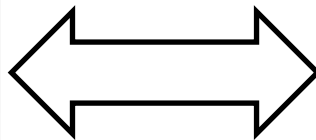
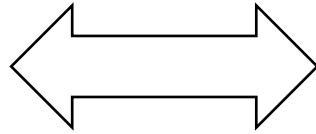

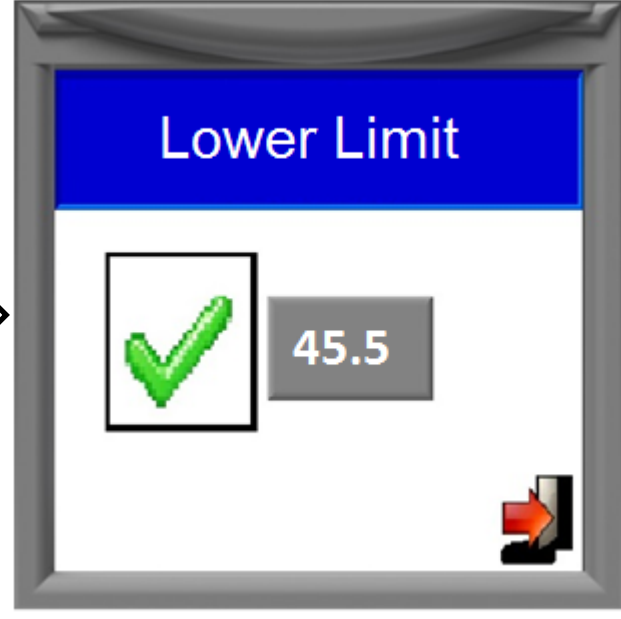
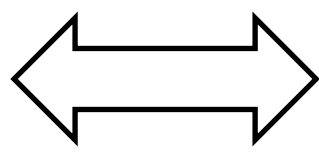
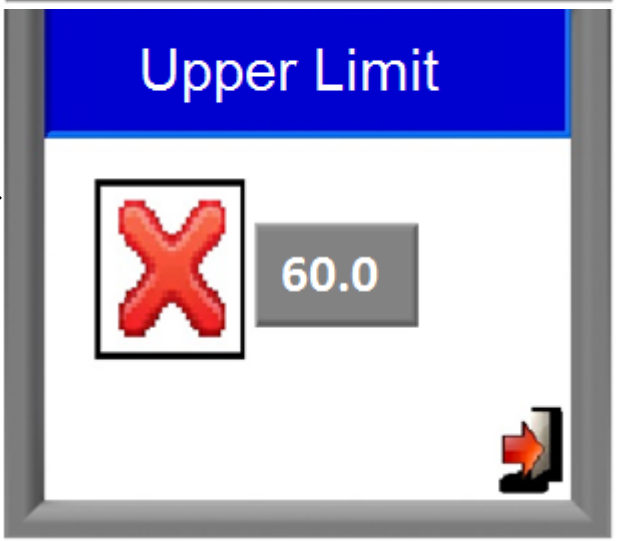
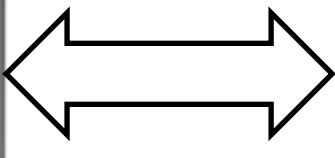
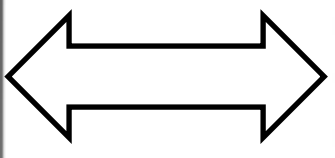



During the pre-load, if overload occurs or wrong application applied related messages shown.

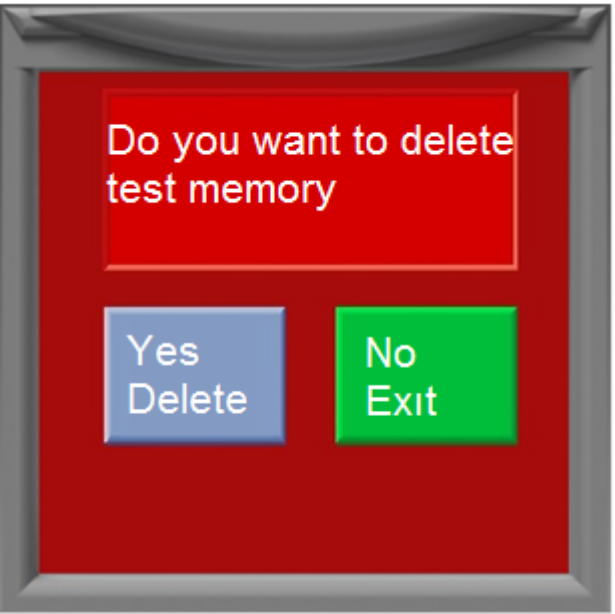
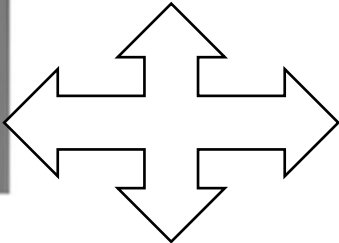

Each of the 100 data capacity, 50 memory zones available. Total data capacity is 5.000

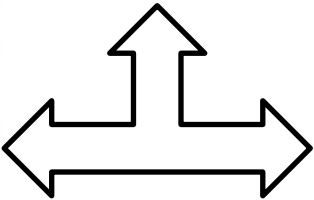



Zones in the memory can easily be restarted & you can examine the results of tests

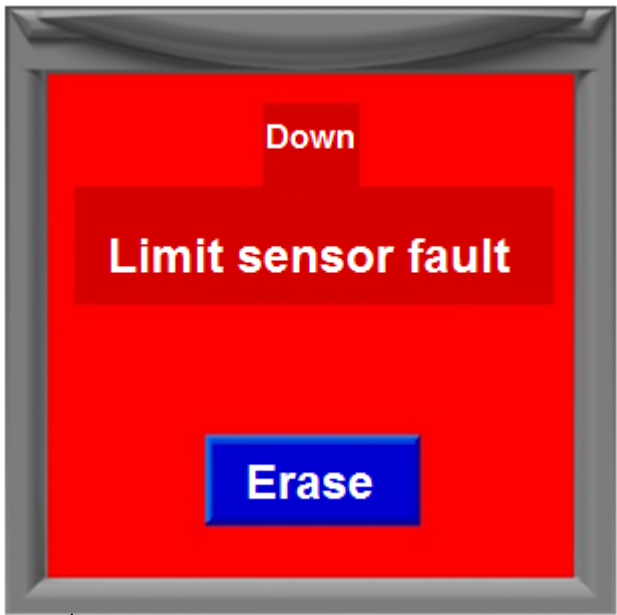
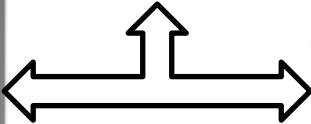
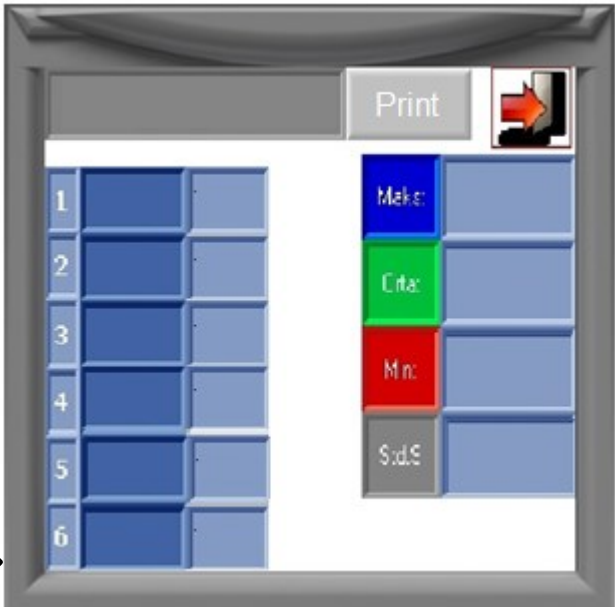

In case of sensor failure warning sign will be shown on the right

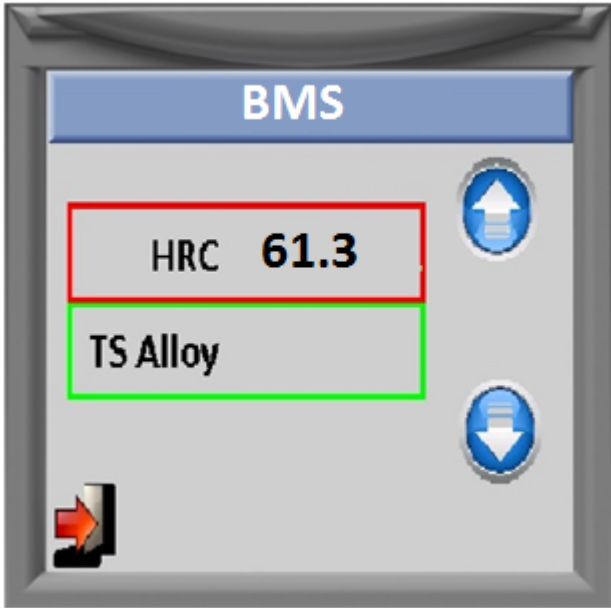

Hardness conversions

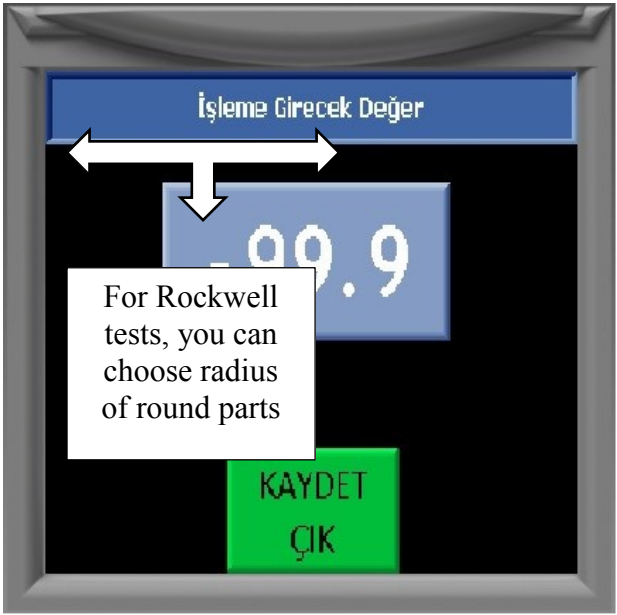
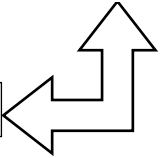

For Rockwell tests, you can choose radius of round parts



## 14 Calibration

**Important Notice:** During calibration, 2 point calibration system used. Therefore, for each calibration, upper and lowest test blocks must be chosen according to test methods. For example, for HRC method, upper block value 62-65 HRC, lowest block value 22-25 HRC arasinda can be chosen.

**Your equipment is calibrated under related EN norms. You do not need to calibrate the equipment again.**

*But, if required, calibration can be made using EN norms by expert persons under suitable conditions. In case of making mistakes during calibration, we recommend to go SETTINGS menu and use FACTORY SETTINGS function. Then, you can return original calibrated values.*

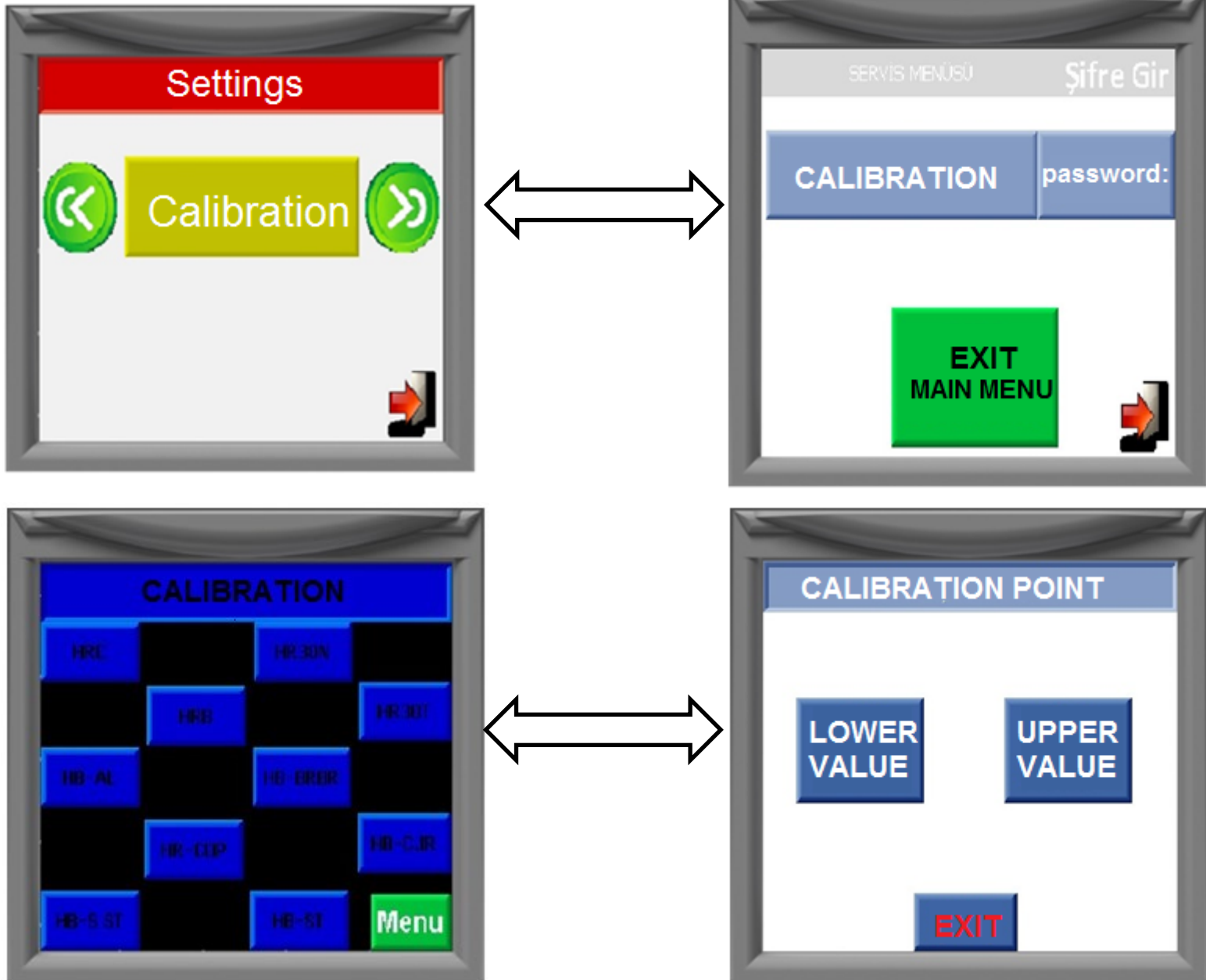

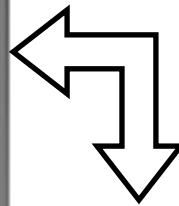
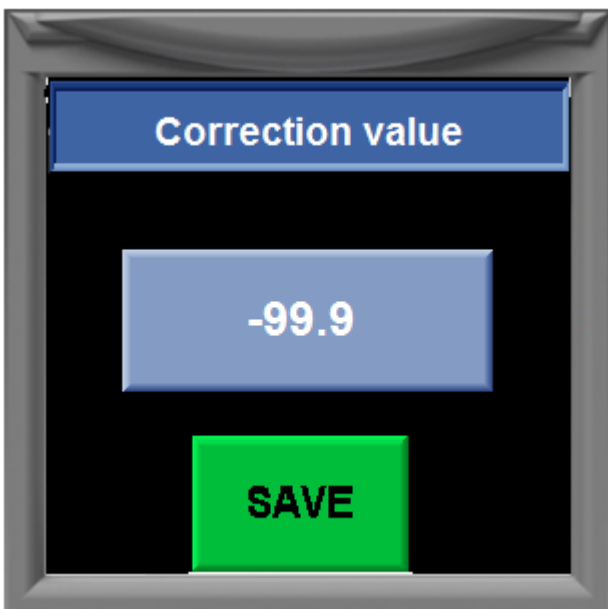
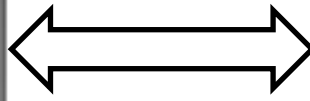

You can add correction values for Brinell methods



To save the calibration values as the factory settings registration password should be requested from our company.  
NOTE: If you done a wrong calibrations as the factory the calibration must be repeated.